

USB-C Voltage Regulator Module for Rosahl M-Series Electric Dehumidifier Membranes.

Available Options

Module	Input	Output	Peripherals on Module
USB-C-VREG2	USB-C 5V	3.0V / 3000mA	<ul style="list-style-type: none"> - 3.0V output voltage for Rosahl M-series micro-dehumidifier - 3000mA rated current - fold-back current limiting - USB-C connector - solder pads for output voltage

Module Overview

The USB-C-VREG2 power supply module is a suitable and compact power supply solution for the Rosahl M-series micro-dehumidifiers from USB-C ports. It delivers 3V DC at 3000mA rated current with fold-back current limiting.

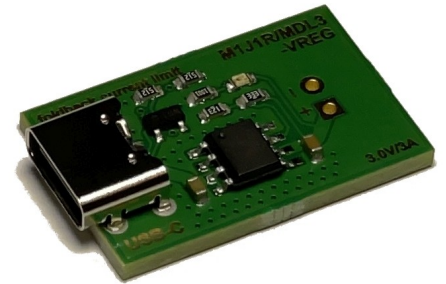

Rosahl Dehumidifier Membranes

Rosahl dehumidifiers are based on a solid-state polymer membrane. When supplied with a 3V DC voltage, moisture on one side is being decomposed into Hydrogen ions and Oxygen, the Hydrogen ions pass the membrane and recombine with air Oxygen to moisture again on the other side and get discharged.

On the right is the Rosahl M-1J1R micro-dehumidifier as example. USB-C-VREG2 can be used with any M-series membranes (see the respective data sheet for power supply requirements).

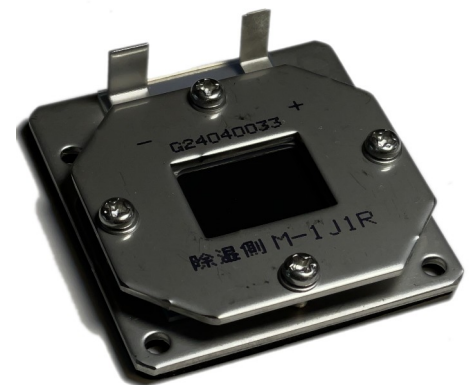

Storage of 3D-Print Filament Spools

Rosahl dehumidifiers are suitable for dry storage of filament spools of various materials for 3D printing. We inspected several storage boxes with regards to their suitability (sealing, capacity, etc.) and selected various Rosahl dehumidifiers for our product range, which turned out well suited. The usually required deccicant (Silica gel), which has to be regenerated periodically, is no longer needed.

With an applicable air volume of 125 liters the Rosahl M-1J1R membrane is suitable for storage of multiple filament spools in boxes or even drying down single spools in a 4l „cereal box“. The pictures show such a solution with a 3D-printed mounting cover/frame and spool rollers with hygrometer mount. The STL files for these are available for download at ... and can be printed on your own.

An additional mounting cover is available for the M-3M1R membrane.

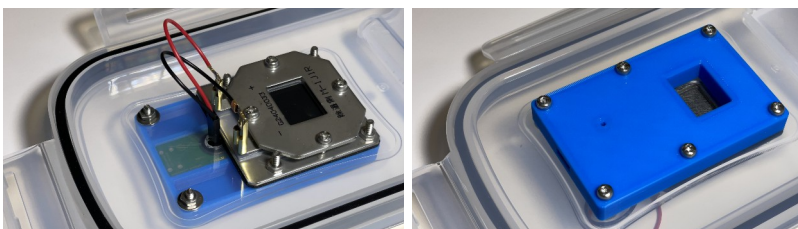

Technical Parameters USB-C-VREG2

Symbol	Parameter	Condition	Min	Typ	Max	Units
VIN	Input Voltage	USB-C	3.3	5.0	5.5	V
VOUT	Output Voltage			3.0		V
IOUT	Output Current ^[1]	rated		3000		mA
	Output Accuracy	85°C			1.5%	
IQ	Quiscent Current			0.6		mA
	Current Limiting		fold-back			
T	Operating Temperature		-40		+85	°C
	Dimensions		16 x 25 x 3.9			mm

Notes

[1]: The voltage regulator of the USB-C-VREG2 is specified for a rated output current of 3000mA. However, with a 5V USB-C supply voltage this leads to a thermal power dissipation of 6W. Continuous operation at 3000mA would hence require cooling. The intended application of the USB-C-VREG2 is with a Rosahl M-series dehumidifier membrane e.g., M-1J1R, M-3M1R which draw high inrush current just during startup and a significantly lower current during continuous operation which does not require any cooling.

Fold-Back Current Limiting

Due to the dehumidifier membranes being intrinsically hygroscopic, they absorb humidity if no supply voltage is present. This moisture needs to be discharged on startup and leads to a significantly higher inrush-current than the regular operating current. During startup the supply voltage shall still not drop below 2V, otherwise moisture discharge is not possible or significantly delayed. Suitable current supplies are fold-back current limiting sources, which regulate the output current further down than pure constant current sources and hence maintain the required minimum supply voltage for the dehumidifier membranes.

The RT9059 voltage regulator used on the USB-C-VREG2 contains an independent current limit and the short circuit current protection to prevent unexpected applications. The current limit monitors and controls the pass transistor's gate voltage, minimum limiting the output current to 3.1A (typical). When the output voltage is less than 0.2V, the short circuit current protection starts the current fold back function and maintains the loading current at maximum 1.8A. The output can be shorted to ground indefinitely without damaging the part.

Power Supply

The USB-C-VREG2 is powered over a USB-C port and the recommended power rating of the used USB power supply would be 15W.

Note: The USB-C-VREG-2 is not an official USB-C PD sink device and might hence not be recognised by certain USB-C power supplies. Best alternative would be a standard min. 15W USB-A power supply with USB-A to USB-C cable.

Connection and Pinout

Right picture shows the USB-C-VREG2 module with USB-C connector to the left and solder pads for the output voltage.

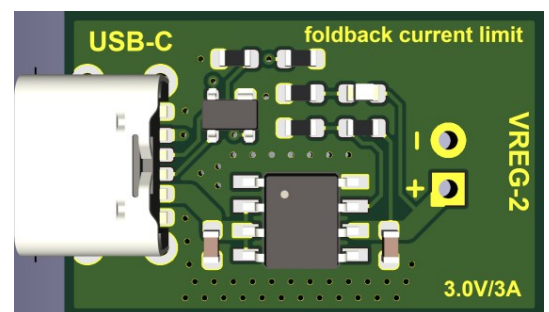

Revision History

- V1.0: First version
- V1.1:
 - changed GND solder pad from direct connect to relief connect for better solderability
 - changed LED color from red to green
 - changed PCB print from „M1J1R/MDL-VREG“ to „VREG-2“
- V1.2:
 - added note to Power Supply section

Declaration of Electro Magnetic Conformity of the CHIP45 „USB-C-VREG2“

CHIP45 voltage regulator modules (henceforth products) are designed for installation in electrical appliances or as dedicated evaluation boards (i.e.: for use as a test and prototype platform for hardware/software development) in laboratory environments.



Caution:

CHIP45 products lacking protective enclosures are subject to damage by ESD and, hence, may only be unpacked, handled or operated in environments in which sufficient precautionary measures have been taken in respect to ESD-dangers. It is also necessary that only appropriately trained personnel (such as electricians, technicians and engineers) handle and/or operate these products. Moreover, CHIP45 products should not be operated without protection circuitry if connections to the product's pin header rows are longer than 3m.

CHIP45 products fulfill the norms of European Union's Directive for Electro Magnetic Conformity only in accordance to the descriptions and rules of usage indicated in this document (particularly in respect to the connectors, power supply and interface to a host appliance).

Implementation of CHIP45 products into target devices, as well as user modifications and extensions of CHIP45 products, is subject to renewed establishment of conformity to, and certification of, Electro Magnetic Directives. Users should ensure conformance following any modifications to the products as well as implementation of the products into target systems.

RoHS 2011/65/EU amended by 2015/863 Compliance

The RoHS compliance of any product so designated is based upon evidence from the producers (manufacturers) of the utilized components comply with the RoHS Directive. Chip45 – Dr. Erik Lins has taken all reasonable steps to confirm producers' statements and other evidence regarding the absence of the restricted substances to support claim of compliance. To the best of our knowledge, the USB-C-VREG2 is RoHS Compliant with RoHS Directive 2011/65/EU and as amended by Directive 2015/863, and without material exemptions according to the underlying manufacturer's documentation.

DISCLAIMER

In this manual are descriptions for copyrighted products that are not explicitly indicated as such. The absence of the trademark (™) and copyright (©) symbols does not imply that a product is not protected. Additionally, registered patents and trademarks are similarly not expressly indicated in this manual.

The information in this document has been carefully checked and is believed to be entirely reliable. However, chip45 – Dr. Erik Lins assumes no responsibility for any inaccuracies. chip45 neither gives any guarantee nor accepts any liability whatsoever for consequential damages resulting from the use of this manual or its associated product. chip45 reserves the right to alter the information contained herein without prior notification and accepts no responsibility for any damages which might result.

Additionally, chip45 – Dr. Erik Lins offers no guarantee nor accepts any liability for damages arising from the improper usage or improper installation of the hardware or software. chip45 – Dr. Erik Lins further reserves the right to alter the layout and/or design of the hardware without prior notification and accepts no liability for doing so.

© Copyright 2024 chip45 – Dr. Erik Lins, 35418 Buseck, Germany.

Rights - including those of translation, reprint, broadcast, photomechanical or similar reproduction and storage or processing in computer systems, in whole or in part - are reserved. No reproduction may occur without the express written consent from chip45 – Dr. Erik Lins.

CONTACT INFORMATION

Address: chip45 – Dr. Erik Lins, Am Rommel 15, 35418 Buseck, Germany
Ordering/Tech. Support: +49 (6408) 5042333 , info@chip45.com
Web Site: <http://www.chip45.com>